

# **BM28 BLE Module Specification**

Version: V1.4

Update Date:September 23,2021

Shenzhen Yilian Internet of Things Co., Ltd. All rights reserved

The specifications of this product are subject to change without notice.

Shenzhen Yilian Internet of Things Co., Ltd. reserves the right to make changes to the specifications and materials contained in it without prior notice, and at the same time damage (including consequential damage) caused by trust in the materials cited, including But not limited to errors in printing and other errors related to this publication, Yilian Internet of Things will not be held responsible.

## Revision History

Revision	Author	Reviewer	Date	Description
V1.0	LUO	ZHU	2020/03/29	Initial Release
V1.1	LUO	ZHU	2020/5/1	Update company information
V1.2	LUO	ZHU	2020/7/16	<ol style="list-style-type: none"> <li>1. Appendix adds authentication data</li> <li>2. Update power consumption parameters to supplement power consumption screenshots</li> <li>3. Modify power-on delay time</li> <li>4. Modify the power range</li> </ol> Add module physical diagram, side view
V1.3	LUO	ZHU	2021/1/26	Update authentication information
V1.4	LUO	ZHU	2021/9/23	<ol style="list-style-type: none"> <li>1. Change: I2C pin definition</li> <li>2. Change: I2C reference circuit diagram</li> <li>3. Change: The maximum value of RF output is 2.5dbm</li> </ol>

## Contents

Revision History.....	- 2 -
Contents.....	- 3 -
1. Overview.....	- 5 -
1.1 Product Overview.....	- 5 -
1.2 Characteristic.....	- 5 -
1.3 Application Field.....	- 6 -
1.4 Module picture.....	- 6 -
2 Module Interface.....	- 7 -
2.1 Size package.....	- 7 -
2.2 Pin definition (UART).....	- 8 -
2.3 Pin definition (I2C) .....	- 8 -
3 Electrical parameters.....	- 9 -
3.1 Absolute electrical parameters.....	- 9 -
3.2 Working conditions.....	- 10 -
3.3 Power Consumption.....	- 10 -
4 RF characteristics.....	- 13 -
4.1 Basic RF characteristics.....	- 13 -
4.2 RF output power.....	- 13 -
4.3 RF receiving sensitivity.....	- 13 -
5 Antenna information.....	- 13 -
5.1 Antenna type.....	- 13 -
5.2 Reduce antenna interference.....	- 13 -
6 Hardware Reference Design.....	- 14 -
6.1 Typical Application Diagram.....	- 14 -
6.2 Design Instructions.....	- 15 -
7 Protocol.....	- 15 -
7.1 Instruction.....	- 15 -
7.2 General transmission.....	- 15 -
7.3 AiLink protocols.....	- 16 -
7.4 Other custom protocols.....	- 16 -
8 Production guidance.....	- 16 -
8.1 Production guidelines.....	- 16 -

8.2 Test gear.....	- 16 -
9 Contact us.....	- 17 -
10 Appendix (Certification).....	- 17 -

## 1. Overview

### 1.1 Product Overview

BM28 BLE module is specially built for intelligent wireless data transmission by Shenzhen ElinkThings Co., Ltd , using Dialog chip, following BLE V5.1 Bluetooth specification.

This module supports UART / I2C interface protocol and has the advantages of low cost, small volume, low power consumption and high transceiver sensitivity. It can realize its powerful function with only a few peripheral components. The protocol can be customized according to customer requirements to meet multi scenario purposes. Depending on the firmware version, multiple master and slave modes can be supported.

The module has passed reach, ROHS, BQB RF certification (refer to appendix).

### 1.2 Characteristic

- Bluetooth V5.1
- Built-in PCB RF antenna
- UART interface
- 32KB OTP memory
- Add-in FLASH:4Mbit (Optional)
- 2.35\_3.0V wide input voltage range
- lowest power consumption, with dormant current as low as 1.5uA
- Support for customer definition of development agreements

## 1.3 Application Field

The module is mainly used in the field of short-range data wireless transmission. It can facilitate the interaction and control between intelligent devices and app.

- ◆ intelligent weighing (scale, body fat weight, nutrition scale, etc.);
- ◆ Sports Health (intelligent rope skipping, pedometer, electric toothbrush, etc.);
- ◆ Smart meter;
- ◆ Smart Medical Device (glucose meter, digital sphygmomanometer, etc.)
- ◆ Sensor Internet of Things et al;

## 1.4 Module picture

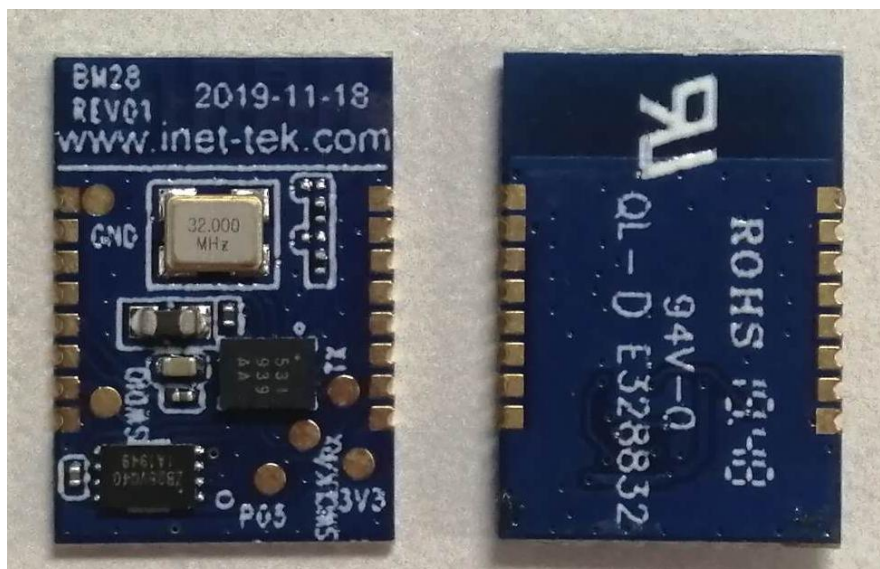

## 2 Module Interface

### 2.1 Size package

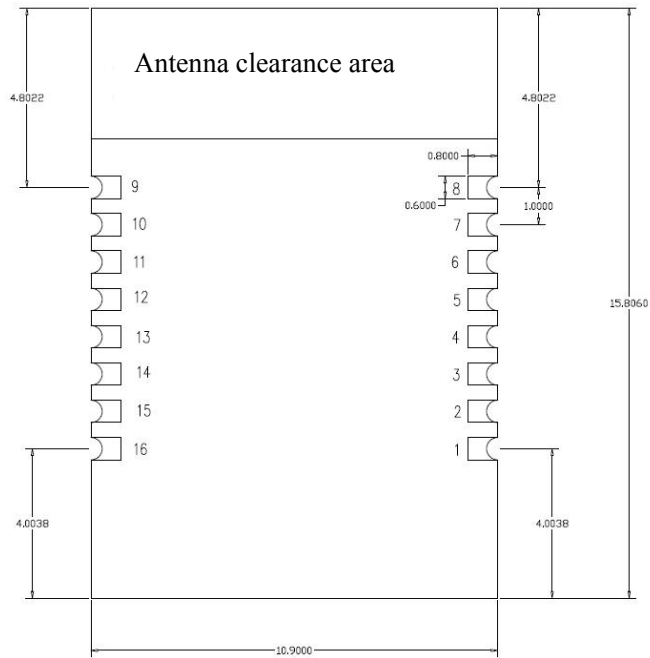

(Unit: mm , Front view)

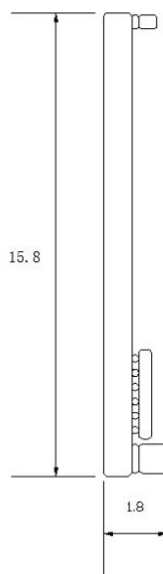

(Unit: mm , Side view)

## 2.2 Pin definition (UART)

PIN	Name	Type	Description
1	VDD <b>[A]</b>	power input	+ 3.0V power supply
2	RX <b>[B]</b>	CMOS input	Serial input
3	TX <b>[B]</b>	CMOS output	Serial output
4	IO/BT_WAKE	IO port	IO
5	IO/BT_CS	BT Connection Status	BT Connection Status : low level : Bluetooth has been connected
6	NC	NC	NC
7	GND	Ground	Ground
8	GND	Ground	Ground
9	GND	Ground	Ground
10	NC	NC	NC
11	NC	NC	NC
12	NC	NC	NC
13	IO	IO port	IO
14	IO	IO port	IO
15	IO	IO port	IO
16	GND	Ground	Ground

注:

**[A]** Operating scope of the power supply: 2.3V~3.0V;

**[B]** Baud rate, 9600 by default

## 2.3 Pin definition (I2C)

PIN	Name	Type	Description
1	VDD <b>[A]</b>	Power input	+ 3.0V power supply
2	INT	Output	Data interrupt port High level: No data Low level: The BM module receives new APP data After MCU reads the data, BM module will clear the data and pull up the port.
3	BT_ST	Output	Bluetooth status pin High level: Bluetooth disconnected



			Low level: Bluetooth connected
4	SCL	SCL	SCL
5	SDA	SDA	SDA
6	NC	NC	NC
7	GND	Ground	Ground
8	GND	Ground	Ground
9	GND	Ground	Ground
10	NC	NC	NC
11	NC	NC	NC
12	NC	NC	NC
13	IO	IO port	IO
14	IO	IO port	IO
15	IO	IO port	IO
16	GND	Ground	Ground

注:

[A] Operating scope of the power supply: 2.3V~3.0V;

## 3 Electrical parameters

### 3.1 Absolute electrical parameters

Parameter	Description	Min	Typical	Max	Unit
Ts	Storage temperature	-50		+150	°C
VDD	Supply voltage	-0.4		3.3	V

### 3.2 Working conditions

Parameter	Description	Min	Typical	Max	Unit
Ta	Working temperature	-40	-	85	°C
VDD	Input voltage	2.35	3.0	3.3	V
VIL	IO low-level input	-0.3	-	VDD+0.3	V
VIH	IO high-level input	VDD-0.3	-	VDD	V
VOL	IO low-level output	VSS	-	VDD+0.3	V
VOH	IO high-level output	VDD-0.3	-	VDD	V

### 3.3 Power Consumption

Parameter	Working conditions	Typical	Remarks
I <sub>Work</sub> (with flash)	Peak current	3.17 mA	
	200ms Broadcast current	163 uA	<a href="#">Figure 1</a>
	20ms Connection current	225 uA	<a href="#">Figure 2</a>
I <sub>Sleep</sub> (without flash)	No broadcast sleep current	2.7uA	
	2000ms Broadcast current	6uA	<a href="#">Figure 3</a>
	2000ms Connection current	145 uA	<a href="#">Figure 4</a>

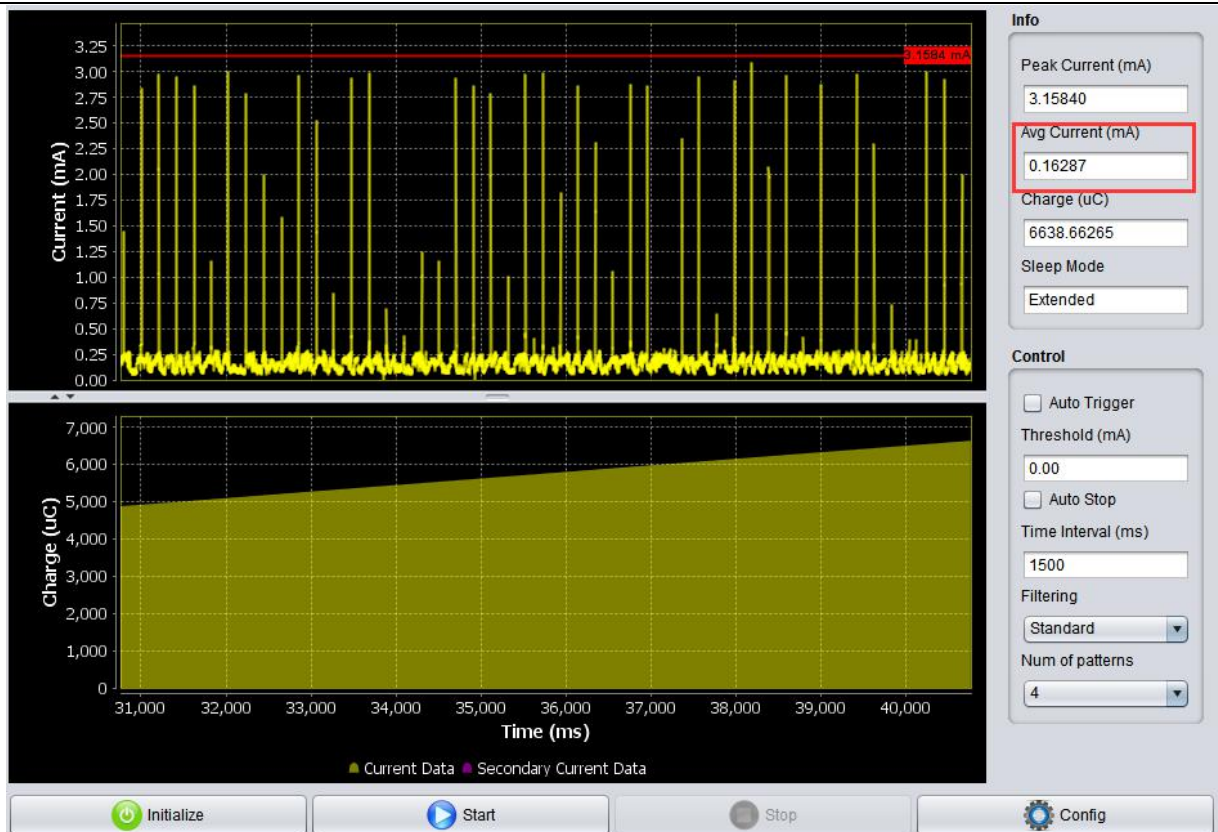

Figure 1: The working average current is not connected

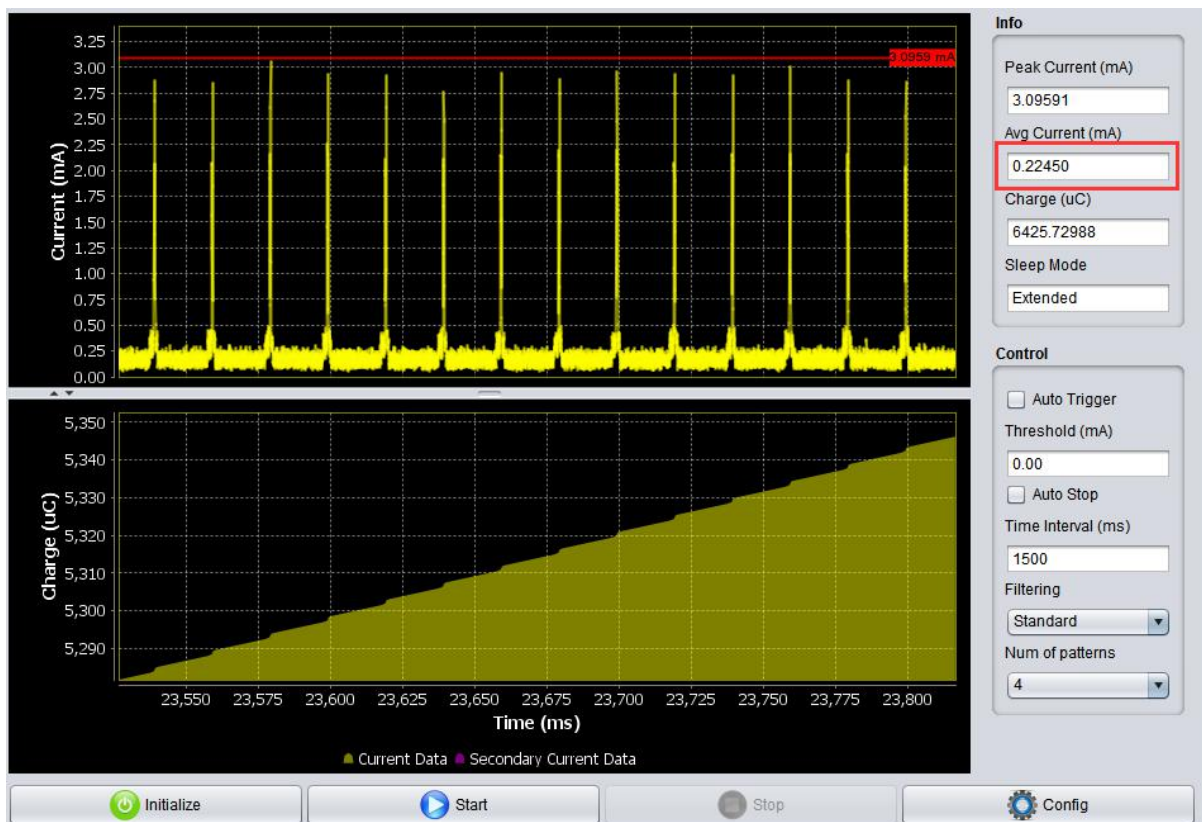

Figure 2: The working average current has been connected

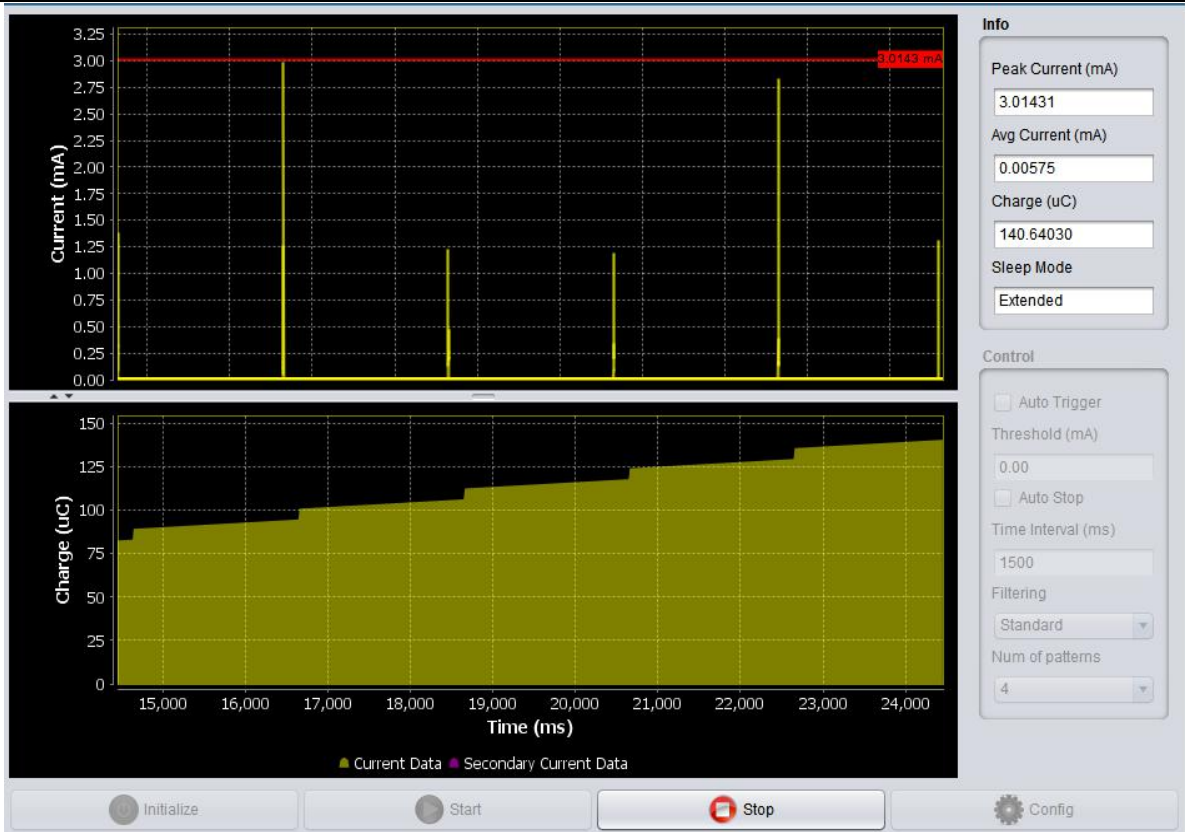

Figure 3: Sleep: The average current is not connected



Figure 4: Sleep has connected to average current

## 4 RF characteristics

### 4.1 Basic RF characteristics

Parameter	Description
Working Frequency	2.4GHz ISM band
Wireless Standard	BLE 5.1
Data Transmission Rate	1Mbps
Antenna type	On-board PCB antenna (default)

### 4.2 RF output power

Parameter	Min	Typical	Max	Unit
RF average output power	-	0	2.5	dBm
20dB occupies bandwidth		1		MHz

### 4.3 RF receiving sensitivity

Parameter	Min	Typical	Max	Unit
RX receiving sensitivity		-90		dBm

## 5 Antenna information

### 5.1 Antenna type

The PCB antenna used is the 2.4GHZ MIFA onboard antenna

### 5.2 Reduce antenna interference

- 5.2.1 Layout note: there shall be no wiring or copper laying under the antenna clearance area of the module.
- 5.2.2 Assembly Note: Ensure clearance height and clearance distance greater than 5MM, to avoid other metal interference with Bluetooth signals.

## 6 Hardware Reference Design

### 6.1 Typical Application Diagram

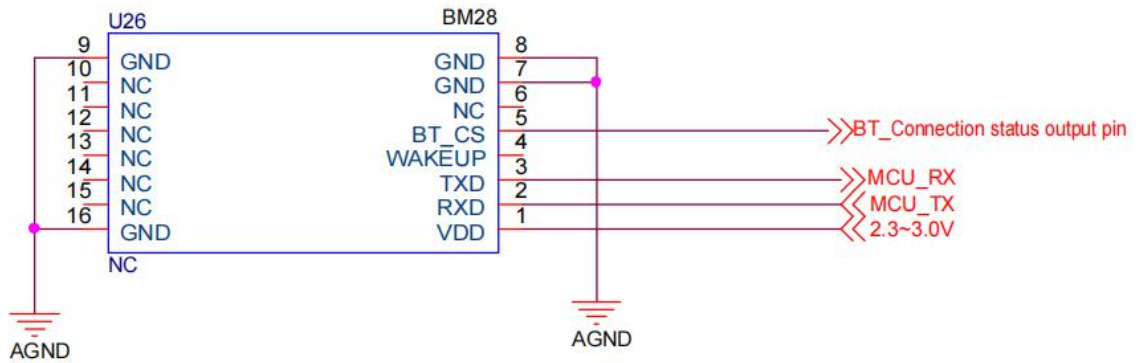

UART interface reference design drawing

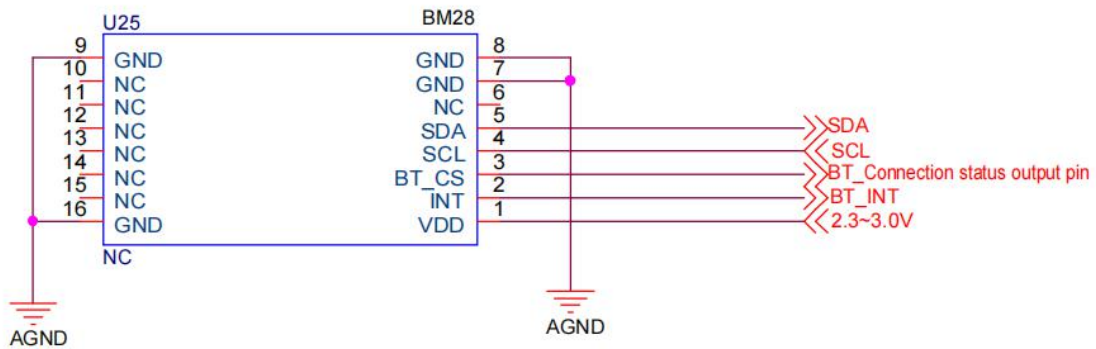

I2C interface reference design drawing

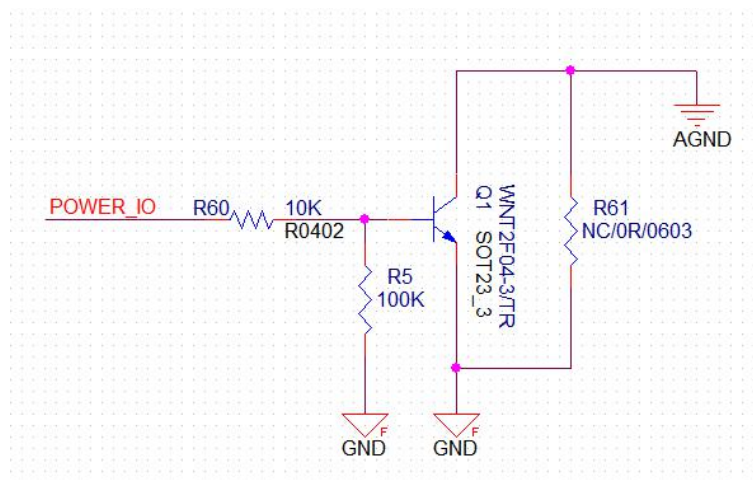

Module power supply control circuit (control module AGND)

(1. Welding R61, is normal power supply mode; 2. Welding R5/R60/Q1, is power-off mode)

## 6.2 Design Instructions

### 6.2.1 BM28 supports normal power mode and power off mode:

Normal power mode - - Bluetooth supports history function;The product does not work and Bluetooth is in low power mode.

Power off mode - Bluetooth will be directly cut off, consuming 0 power current, but Bluetooth module cannot support history function;You can supply power when you need it again.

### 6.2.2 Normal power mode: It can be put into low frequency broadcasting mode by serial command, referring to the communication protocol specifically.

### 6.2.3 Power off mode: The power supply will be switched off directly.

### 6.2.4 Power Up Requirements:

When the module **with flash**: module is powered up, power the module to the normal power voltage, and then **delay 400ms (with flash)** to send data to the RX/TX communication interface. Please note that the voltage and text wave do not exceed the limit requirements to avoid damage to the module.

When the module **without flash**: module is powered up, power the module to the normal power voltage, and then **delay 200ms (without flash)** to send data to the RX/TX communication interface. Please note that the voltage and text wave do not exceed the limit requirements to avoid damage to the module.

### 6.2.5 PCB LAYOUT Recommendation:

The feet are long and wide: 1.8mm\*0.7mm;

The foot position center spacing (vertical) is: 1.0mm;

The foot position center spacing (transverse) is: 10.9mm;

## 7 Protocol

### 7.1 Instruction

The communication protocol is related to the firmware version of the module, and the specific protocol functions shall be subject to the firmware version. Different protocol functions and application scenarios are completely different. Generally speaking, it supports Bluetooth master mode and can scan and connect other Bluetooth devices; Bluetooth slave mode is mainly used for transparent transmission similar to Bluetooth. Special commands and interfaces are required when there is a special protocol.

### 7.2 General transmission

Universal transmission is supported by default, and users can configure module parameters.Refer to

## 7.3 AiLink protocols

To facilitate customers to develop AiLink series products, this module has corresponding protocols to support AiLink protocol, AiLink APP and platform, referring to the corresponding AiLink product application manual, such as ailink frontal temperature gun application manual:

<http://www.elinkthings.com/cn/help-detail-171.html> .

## 7.4 Other custom protocols

To meet the different customer needs, this module can provide a high degree of customer protocol customization requirements, each customized module will have a new firmware version number, please contact our sales staff.

# 8 Production guidance

## 8.1 Production guidelines

- 8.1.1 Steel mesh ---- when opening the steel mesh, be sure to open the hole of the module pad. Please open the steel mesh at the ratio of 1:1 and then expand it outward by 0.7mm, with the thickness of 0.12mm.
- 8.1.2 Hold ----- when you need to hold the module, you can't hold it with bare hands. You must wear gloves and electrostatic ring.
- 8.1.3 Plant ambient temperature and humidity-----  $\cong 30^{\circ}\text{C}$  ,  $\cong 60\% \text{R.H.}$
- 8.1.4 Baking - baking temperature 125  $^{\circ}\text{C}$ , 8 hours.
- 8.1.5 Furnace pass ----- the furnace pass temperature shall be determined according to the requirements of the customer's main board.

## 8.2 Test gear

To ensure product quality and customer production efficiency, we provide the corresponding test and treatment tools. Please refer to the BM Series Test Box Description. Please contact our company for obtain



## 9 Contact us

Shenzhen Yilian Internet of Things Co., Ltd.

Address: Room 502, 5th Floor, Building A, Qiaohongsheng Cultural and Creative Park, Yintian Industrial Zone, Xixiang Street, Baoan District, Shenzhen

Tel: + (86) 0755-81773367

Email: [hw@elinkthings.com](mailto:hw@elinkthings.com)

Web: [www.elinkthings.com](http://www.elinkthings.com)

## 10 Appendix (Certification)

SGS REACH

### TEST REPORT

**APPLICANT** : ShenZhen Elink Things Co. ,LTD

**PRODUCT NAME** : BM28

**MODEL NAME** : BM28

**BRAND NAME** : N/A

**TEST REQUEST** : As specified by client, to screen 205 substances in the Candidate List of Substances of Very High Concern (SVHC) for authorization published by European Chemicals Agency (ECHA) regarding Regulation (EC) No 1907/2006 concerning the REACH in the submitted sample(s).

**RECEIPT DATE** : 2020-06-11

**TEST DATE** : 2020-06-11 to 2020-06-16

**ISSUE DATE** : 2020-06-18

**SUMMARY:**

According to the ruling of the court of Justice of the European Union on the definition an article under REACH, and the specified scope and evaluation screening, the test results of SVHC are <0.1%(w/w) in the submitted sample



Edited by : Deng Baijian  
Deng Baijian (Rapporteur)

Approved by : XiaoShan Ni  
Xiaoshan Ni (Supervisor)

SGS ROHS

## TEST REPORT

**Applicant** : ShenZhen Elink Things Co. ,LTD  
**Product Name** : BM28  
**Model Name** : BM28  
**Brand Name** : N/A  
**Test Request** : With reference to RoHS Directive 2015/863/EU amending 2011/65/EU  
**Receipt Date** : 2020-06-11  
**Test Date** : 2020-06-11 to 2020-06-16  
**Issue Date** : 2020-06-18  
**Conclusion** : Based on the performed tests on submitted sample(s),the results of Lead, Mercury, Cadmium, Hexavalent chromium, Polybrominated biphenyls (PBBs),Polybrominated diphenyl ethers (PBDEs) and Phthalates such as Bis (2-ethylhexyl) phthalate (DEHP), Dibutyl phthalate (DBP), Butyl benzyl Phthalate (BBP), Diisobutyl phthalate (DIBP) comply with the limits as set by RoHS Directive (EU) 2015/863 amending Annex II to Directive 2011/65/EU.



Edited by : Deng Baijian  
Deng Baijian (Rapporteur)

Approved by : Xiaoshan Ni  
Xiaoshan Ni (Supervisor)

BQB RF TEST

## TEST REPORT

**APPLICANT** : ShenZhen Elink Things Co. ,LTD  
**PRODUCT NAME** : BM28  
**MODEL NUMBER** : BM28  
**BRAND NAME** : Elink Things  
**BLUETOOTH VERSION** : 5.1  
**STANDARD(S)** : Bluetooth Low Energy RF-PHY Test Specification  
RF-PHY.TS.p15  
**RECEIPT DATE** : 2020-06-15  
**TEST DATE** : 2020-06-15 to 2020-07-06  
**ISSUE DATE** : 2020-07-08



Edited by:     Liu Su      
Liu Su (Rapporteur)

Approved by:     Li Dong      
Li Dong (Supervisor)